

Manual
DALI-2 presence sensor
PlanoSpot 360 DALI-2 S DE



Contents

1	General	3
	1.1 Safety information	3
	1.2 Proper use	3
	1.3 Explanation of terms	3
2	Function description	4
	2.1 Overview of available instances	4
3	Technical data	5
4	Product characteristics	6
	4.1 Usage	6
	4.2 Functionality	6
	4.3 Dimensions	7
	4.4 Detection area	8
	4.5 Infrared receiver	9
	4.6 Display/visualisation	9
5	Connection	11
6	Installation	12
	6.1 Ceiling installation	12
7	Operation	13
	7.1 Settings via remote control	13
	7.2 Settings via the DALI bus	18
	7.3 Status messages via the DALI bus	18
8	Light measurement	19
	8.1 Light measurement	19
	8.2 Determining a value via the DALI bus	20
9	Operating modes	21
	9.1 Memory bank 2 – occupancy sensor	21
	9.2 Memory bank 3–6 – light sensors	21
	9.3 Memory bank 7–11 – button instance	22
	9.4 Start-up behaviour	24
	9.5 Addressing	24
	9.6 Presence	24
	9.7 Brightness	24
	9.8 Button function	25
10	Accessories	27
11	Contact	29

1 General

1.1 Safety information



ATTENTION

Installation should only be carried out by a qualified electrician!

1.2 Proper use

The PlanoSpot 360 DALI-2 S is intended for indoor installation. It serves as a DALI-2 input device and transmits the collected sensor data to the multi-master application controller. The PlanoSpot 360 DALI-2 S is exclusively intended for use as contractually agreed between the manufacturer and the user. Any other use is considered to be unacceptable. The manufacturer does not accept liability for any resulting damages.

1.3 Explanation of terms

There is a difference between motion detectors and presence detectors. Motion detectors can only detect large movements. Presence detectors, on the other hand, can detect even the smallest of movements – those made while seated, for example. DALI-2 sensors can detect both large and small movements and are therefore referred to as presence sensors. However, the implementation of the motion detection function in line with IEC 62386 Part 303 is based on the concept of a "movement based sensor".

This manual only describes operating mode 0x00.

2 Function description

The PlanoSpot 360 DALI-2 S devices are integrated into a higher-level system. Thanks to the DALI-2 standard, a multi-master application controller from any manufacturer may be used. This controller must support IEC 62386 Parts 101/103 and optionally – in order to use the information regarding presence as well as brightness – Parts 303/304.

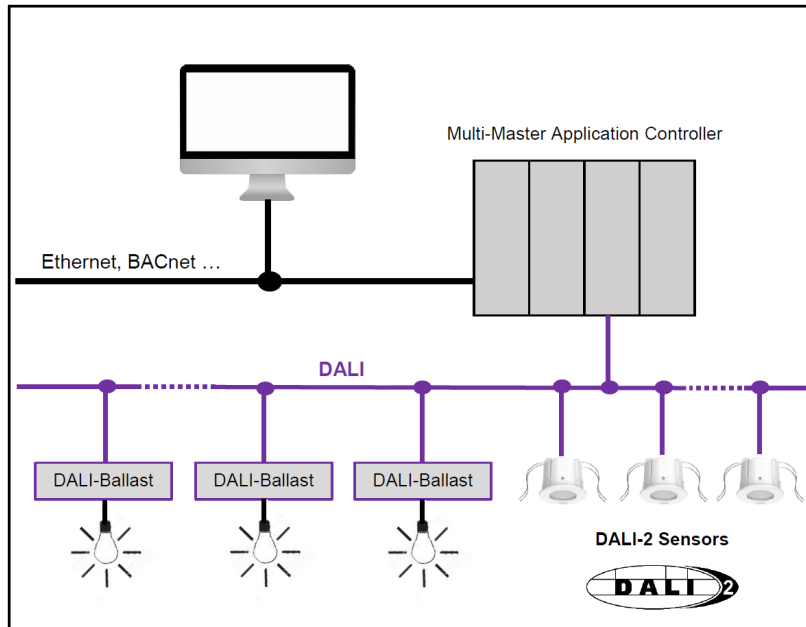

The PlanoSpot 360 DALI-2 S devices and other DALI components are connected to the DALI line. The DALI supply is provided by the higher-level system. The assignment of the short addresses and the selection of the required instances for the PlanoSpot 360 DALI-2 S devices are carried out via the multi-master application controller.

After start-up, the PlanoSpot 360 DALI-2 S supply information regarding room occupancy and motion detection as well as brightness values to the higher-level controller via the relevant instances. The lighting and other systems in a building are controlled on the basis of this information.

2.1 Overview of available instances

Instance no.	Instance name	Instance type	Standard	Memory bank
0	Occupancy sensor Standard detection zone	3	IEC 62386-303	2
1	Occupancy sensor Reduced detection zone	3	IEC 62386-303	2
2	Light sensor, integral	4	IEC 62386-304	3
3	Light sensor, interior	4	IEC 62386-304	4
4	Light sensor, middle	4	IEC 62386-304	5
5	Light sensor, window	4	IEC 62386-304	6
6 / 7	Push button on / off	1	IEC 62386-301	7
8 / 9	Push button on / off	1	IEC 62386-301	8
10 / 11	Push button on / off	1	IEC 62386-301	9
12	Push button scene 1	1	IEC 62386-301	10
13	Push button scene 2	1	IEC 62386-301	11

3 Technical data

Operating voltage	DALI (in accordance with IEC 62386-101): 10 V – 22.5 V
Power input	max. 10 mA
Connection type	Plug-in terminals
Cable cross-section	0.5 – 1.5 mm ²
Type of installation ¹	Ceiling installation with springs
Size of flush-mounted housing	Size 1 (NIS, PMI)
Recommended installation height	2.0 – 3.0 m / max. 3.5 m
Minimum height	> 1.7 m
Detection area, horizontal	360°
Detection area, walking ²	7.0 x 7.0 m 49 m ²
Detection area, seated ³	4.5 x 4.5 m 20 m ²
Light measurement	approx. 10 – 10,000 lux
Protection rating	IP 20
Ambient temperature	0 °C to +50 °C
CE Declaration of Conformity	This device corresponds to EN 60669-2-5.
RCM conformity	This device is compliant with the ACMA guidelines.
DALI conformity	IEC 62386-101/103/303/304

¹ Surface-mounted installation also possible with accessories

² Transverse movement with an installation height of 3 m, standard detection zone

³ Seated with an installation height of 3 m, standard detection zone

4 Product characteristics

4.1 Usage

The focus is on purpose-built facilities, within the following applications in particular:

- Offices
- Large offices
- School rooms
- Conference rooms
- Corridors

4.2 Functionality

- The PlanoSpot 360 DALI-2 S provides information about presence and brightness in the form of a DALI telegram in line with IEC 62386 Part 303/304.
- 3 mixed light measurements
- Easy to calibrate brightness measurement
- Square detection area for accurate and easy planning
- Optics can be tilted to adjust the detection area
- Test mode for checking function and detection area
- Configurable detection sensitivity
- Can be configured via DALI bus or remote control
- The theSenda S or theSenda B user remote controls can be used to dim or switch the lamps, to control the blinds, or to execute additional functions via the higher-level control.
- Flat design with interchangeable bezel frame in different colours
- Ceiling installation with springs
- Surface-mounted installation possible with 75B back box (optional)
- theSenda S user remote control (optional)
- theSenda B app remote control (optional) and corresponding theSenda Plug app (for iOS/Android)

All of the product characteristics are described in detail in the following sections.

4.3 Dimensions

4.3.1 Ceiling installation with springs

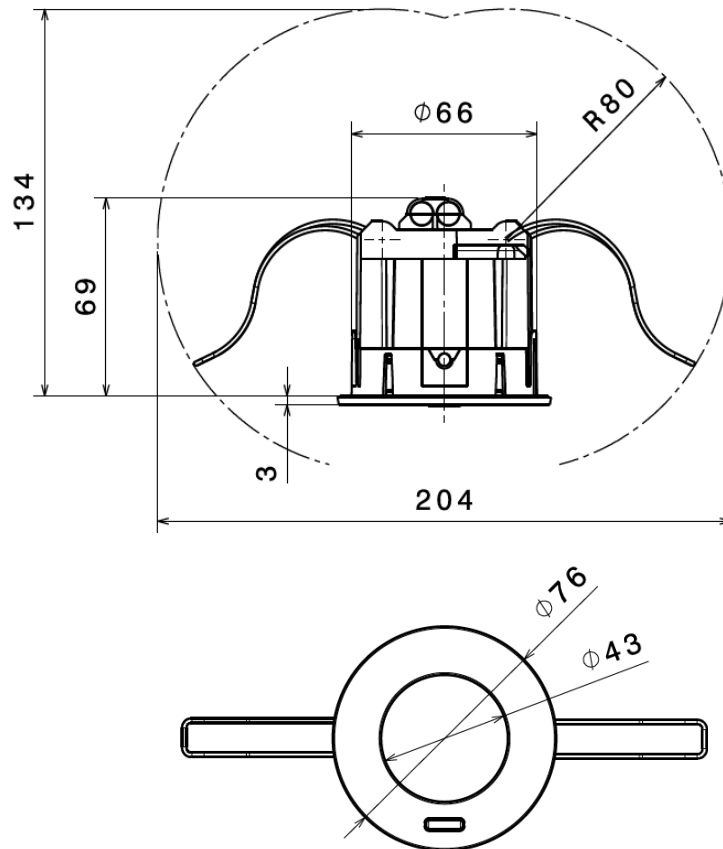

4.3.2 Surface-mounted installation with 75B back box

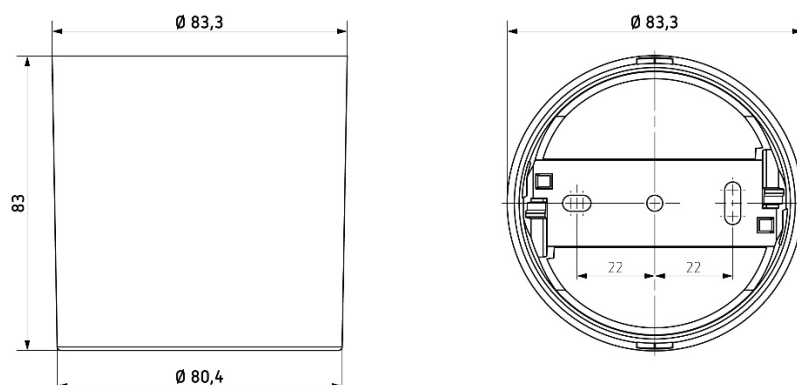

4.4 Detection area

The square detection area of the PlanoSpot 360 DALI-2 S presence sensor guarantees accurate and simple planning. There are 2 detection zones available.

i Note that seated and walking persons are detected in differently sized areas.

The recommended installation height is 2–3 m. As installation height increases, the sensitivity of the PlanoSpot 360 DALI-2 S decreases. At an installation height of 3 m or higher, walking motions are necessary and the detection areas of several PlanoSpot 360 DALI-2 S devices should overlap in the marginal zones. The detection range reduces as the temperature increases, and the sensitivity can be adjusted in 5 increments via the DALI bus or with the theSenda B/app remote control.

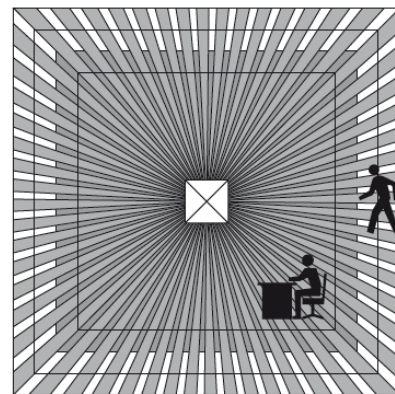
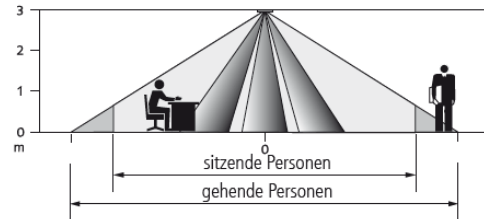

Seated persons

The PlanoSpot 360 DALI-2 S reacts very sensitively to the slightest movements. The details refer to very slight movements at table height (approx. 0.8 m).

Walking persons

From an installation height of > 3 m, the size of and distance between the active and passive zones increase. More pronounced movements are required for clear detection.

Standard detection zone

Installation height (A)	Transverse (t)		Seated (s)	
	Area	Dimensions	Area	Dimensions
2.0 m	20 m ²	4.5 m x 4.5 m	9 m ²	3.0 m x 3.0 m
2.5 m	36 m ²	6.0 m x 6.0 m	16 m ²	4.0 m x 4.0 m
3.0 m	49 m ²	7.0 m x 7.0 m	20 m ²	4.5 m x 4.5 m
3.5 m	64 m ²	8.0 m x 8.0 m	–	–

Reduced detection zone

Installation height (A)	Transverse (t)		Seated (s)	
	Area	Dimensions	Area	Dimensions
2.0 m	4 m ²	2.1 m x 2.1 m	4 m ²	2.0 m x 2.0 m
2.5 m	9 m ²	3.0 m x 3.0 m	6 m ²	2.5 m x 2.5 m
3.0 m	14 m ²	3.8 m x 3.8 m	9 m ²	3.0 m x 3.0 m
3.5 m	22 m ²	4.7 m x 4.7 m	–	–

Detection areas according to sensNORM, see data sheet

By tilting the optics manually, the detection area can be shifted towards the window or the interior by 0.5 to 1 m, depending on the installation height.

4.5 Infrared receiver

An infrared receiver can be used to receive parameters and control commands. This process involves unidirectional communication. The PlanoSpot 360 DALI-2 S can be operated with the following remote controls:

- theSenda B/theSenda Plug remote control (9070985)
- theSenda S user remote control (9070911)
- theSenda P installation remote control (9070910) (limited functional support, see section 7.1 Settings via remote control)

4.6 Display/visualisation

The various statuses of the PlanoSpot 360 DALI-2 S are indicated via a red LED. The LED is located under the lens. The following statuses are indicated in descending priority:

IR command accepted:

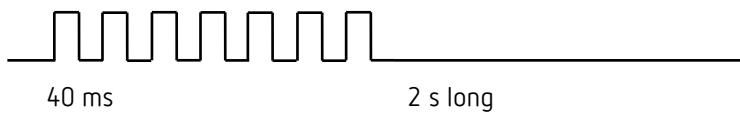

Flickering (12.5 Hz) when a valid remote control command is received.

IR command rejected:

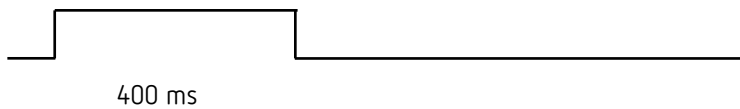

Rejection pulse when an invalid remote control command is received.

Error flashing:

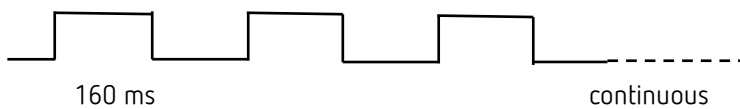

Error flashing. Applies until the error has been resolved.

Identify device:

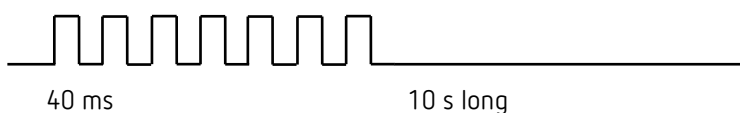

Identification of the sensor by means of the DALI command "IDENTIFY DEVICE"

No short address:

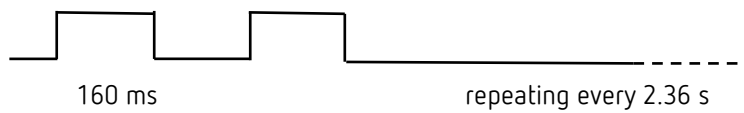

No short addresses assigned to the sensor

Presence test:

LED lights up if motion is detected, otherwise switched off; applies until presence test is completed.

Start-up phase:

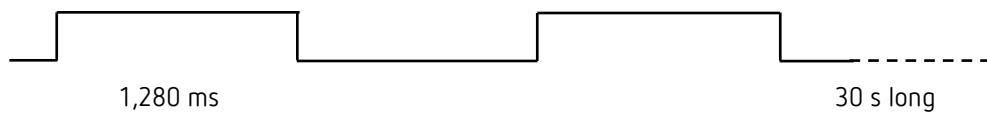

Start-up flashing

5 Connection

The PlanoSpot 360 DALI-2 S devices are connected to the DALI line.

- i An external DALI supply is required for operation of the PlanoSpot 360 DALI-2 S devices. This DALI supply must be able to ensure a reliable power supply for all connected DALI participants.
- i A minimum current of 10 mA per PlanoSpot 360 DALI-2 S must be provided.

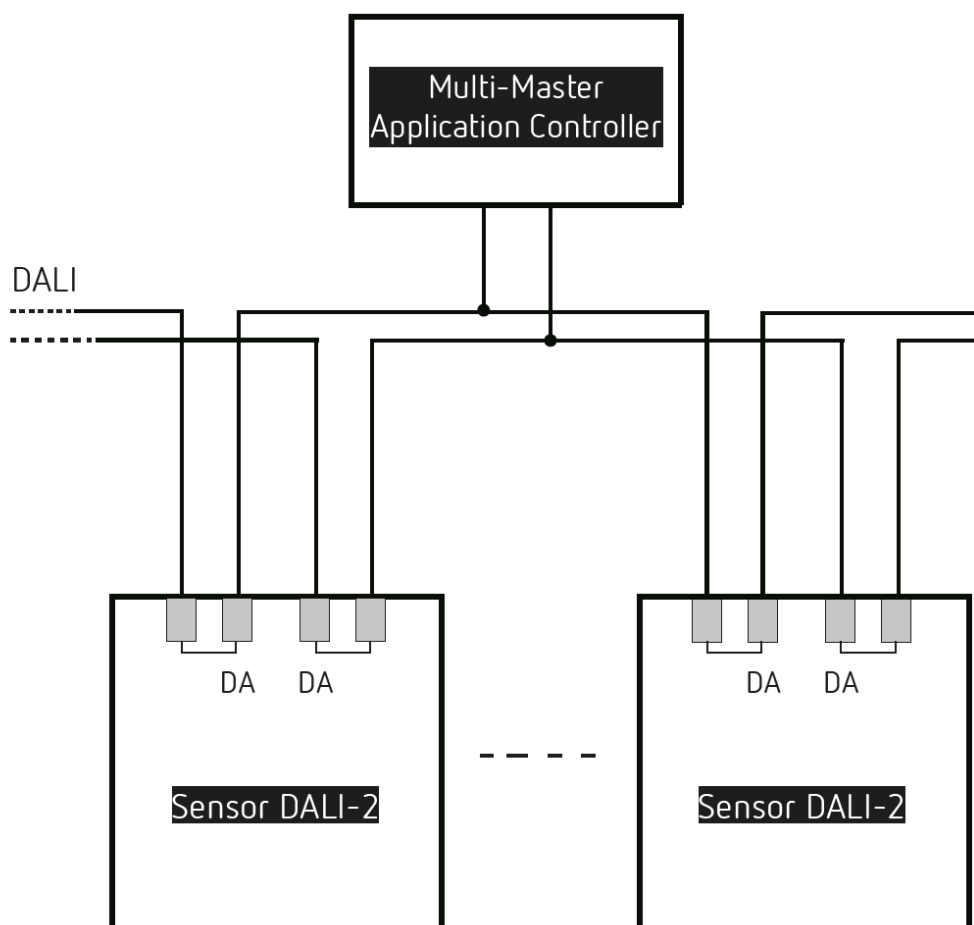

6 Installation

6.1 Ceiling installation

Installation in false ceilings for ceiling thicknesses of 0.5 mm to 3 cm. The drill diameter for the ceiling cut-out is 68 mm. Remove the contact protection (a) and connect the DALI cable with plug-in terminal (b). Implement cable strain relief with cable tie, put on contact protection (c).

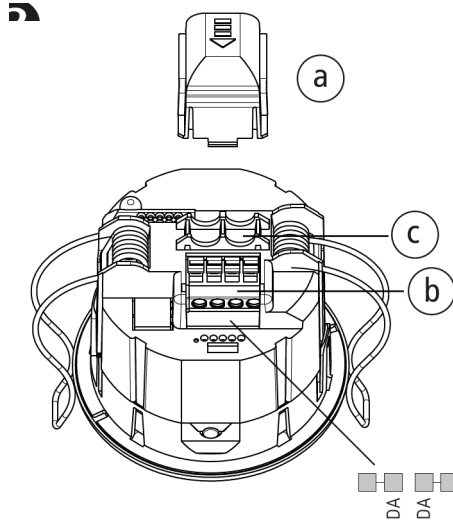

Open springs and mount detector in ceiling (d). Pay attention to window / interior alignment (e). Remove installation protection (f). Align the detection area as required, by tilting the optics by 12° to the right (I) or left (II) (g). Snap on the bezel frame provided (h).

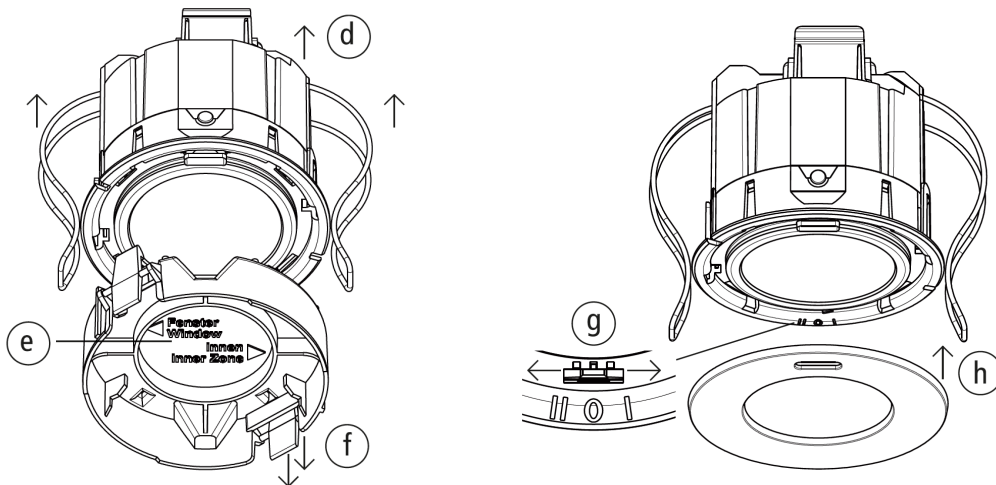

7 Operation

All settings are configured via the DALI bus or the remote control.

i In its initial delivery condition, the PlanoSpot 360 DALI-2 S does not have a short address.

7.1 Settings via remote control

The theSenda B/app and theSenda P remote controls can be used to set the following parameters and control commands.

7.1.1 Parameters

Parameter	Description	Can be queried via app	Can be changed via app	Can be changed via theSenda P
Room correction factor Int/2	Integral room correction factor, instance 2 Range 0.05 .. / 0.3 / ... 2.00	✓	✓	-
Brightness measurement value Int/2	Lux meter brightness value For calibrating the integral brightness measurement, instance 2	-	✓	-
Room correction factor Inn/3	Interior room correction factor, instance 3 Range 0.05 .. / 0.3 / ... 2.00	✓	✓	-
Brightness measurement value Inn/3	Lux meter brightness value For calibrating the interior brightness measurement, instance 3	-	✓	-
Room correction factor Mid/4	Middle room correction factor, instance 4 Range 0.05 .. / 0.3 / ... 2.00	✓	✓	-
Brightness measurement value Mid/4	Lux meter brightness value For calibrating the middle brightness measurement, instance 4	-	✓	-
Room correction factor Win/5	Window room correction factor, instance 5 Range 0.05 .. / 0.3 / ... 2.00	✓	✓	-
Brightness measurement value Win/5	Lux meter brightness value For calibrating the window brightness measurement, instance 5	-	✓	-
Detection sensitivity (PIR)	Increment 1 / 2 / 3 / 4 / 5 All instances	✓	✓	✓
Detection zone	No function in mode 0x00.	-	✓	-
Operating mode	Selection of DALI operating mode 0x00 / 0x80 / 0x81	✓	✓	-
IR group address A	IR group address button instance 6–7 Range: I/II/III/ .. /VIII/All	-	✓	-

IR group address B	IR group address button instance 8–9 Range: I/II/III/ .. /VIII/All	-	✓	-
IR group address C	IR group address button instance 10–11 Range: I/II/III/ .. /VIII/All	-	✓	-
IR group address D	IR group address button instance 12 Range: I/II/III/ .. /VIII/All	-	✓	-
IR group address E	IR group address button instance 13 Range: I/II/III/ .. /VIII/All	-	✓	-
LED display – no short address	Selection of LED display if no short address is assigned "Permit flashing" / "Suppress flashing"	-	✓	-

Bold indicates default values / factory settings

Room correction factor / brightness measurement value

The room correction factor is a measurement for the difference between brightness measurements on the ceiling and the work area. The brightness value on the ceiling is influenced by the installation location, the incidence of light, the position of the sun, the weather conditions, as well as the reflection properties of the room and the furniture.

With the room correction factor, the measured brightness value is adjusted to the conditions in the room and in this way can be matched to the lux meter value (1) measured at the surface beneath the PlanoSpot 360 DALI-2 S.

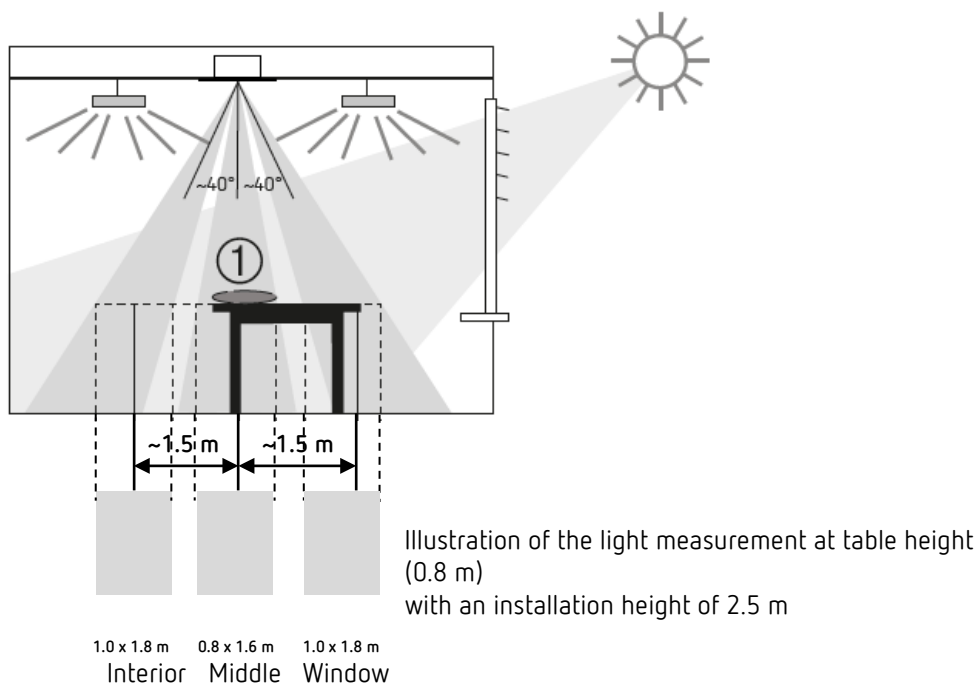

$$\text{Room correction factor} = \frac{\text{Brightness value on the ceiling}}{\text{Brightness value on the work surface}}$$

We recommend the following procedure:

- Place the lux meter or theSenda B remote control with integrated lux meter on the work surface under the PlanoSpot 360 DALI-2 S, enter the measured lux value via theSenda B/app remote control (parameters <Brightness measurement value Int/2, Inn/3, Mid/4, Win/5>) and send to the PlanoSpot 360 DALI-2 S.

i During lux measurements, observe the relevant distances (see illustration above).



- Carry out all measurements at table height.
 - <Brightness measurement value Int/2>: Average of all 3 lux measurements Inn/3, Mid/4, Win/5.
 - <Brightness measurement value Inn/3>: Lux measurement towards the interior
 - <Brightness measurement value Mid/4>: Lux measurement in the middle (below PlanoSpot 360 DALI-2 S)
 - <Brightness measurement value Win/5>: Lux measurement towards the window
- The room correction factor is calculated from this automatically. Values between 0.05 and 2.0 are permitted. Calculated or entered values outside the permitted range are automatically set to the appropriate limit value.
- The calculated room correction factor is adopted. The room correction factor can be checked via the <Room correction factor Int/2, Inn/3, Mid/4, Win/5> parameter for monitoring purposes.

i The standard value is 0.3 and is suitable for most applications. Changes are only sensible in strongly deviating situations.

Detection sensitivity

The PlanoSpot 360 DALI-2 S has 5 sensitivity increments. The basic setting is the middle increment (3).

Increments 1 to 5 can be selected and sent to the PlanoSpot 360 DALI-2 S with the theSenda B/app remote control.

On the theSenda P installation remote control, the sensitivity can be decreased by one increment each time the button  is pushed or increased with the  button.

Value range

Increment	Sensitivity
1	Very insensitive
2	Insensitive
3	Standard
4	Sensitive
5	Very sensitive

Detection zone

It is possible to choose between the "standard" and "reduced" detection zones. This setting is only possible in operating mode 0x80 or 0x81, see separate manual. In operating mode 0x00, the PlanoSpot 360 DALI-2 S rejects this command.

Operating mode

In its factory settings, the PlanoSpot 360 DALI-2 S is set to DALI-2 standard (operating mode 0x00).

The proprietary DALI mode 0x80 or 0x81 was used for older systems. If the PlanoSpot 360 DALI-2 S is to be integrated into such a system, the relevant operating mode – 0x80 or 0x81 – can be selected. There is a separate manual for operating modes 0x80 and 0x81.

IR group address

The button instances of the PlanoSpot 360 DALI-2 S and the buttons on the user remote controls are linked with each other via an IR group address. This means that adjacent PlanoSpot 360 DALI-2 S devices can be separated from each other.

The button instances of the PlanoSpot 360 DALI-2 S are only actuated if the IR group address of the button instance matches that of the user remote control.

Users can choose from I, II, III, IV, V, VI, VII, VIII and All for the IR group addresses. In the case of the PlanoSpot 360 DALI-2 S presence sensor, the "IR group address" parameters are assigned to the following button instances:

- IR group address A Button instance 6 and 7
- IR group address B Button instance 8 and 9
- IR group address C Button instance 10 and 11
- IR group address D: Button instance 12
- IR group address E: Button instance 13

Further information can be found in section 9.8 Button function.

LED display – no short address

If a PlanoSpot 360 DALI-2 S has not yet received a short address, this can be indicated via the red LED. In order for this to happen, the parameter must be set to "Permit flashing", otherwise it should be set to "Suppress flashing".

7.1.2 Control commands

Control command	Description	Can be triggered via app	Can be triggered via theSenda P
Quiescent mode	On/Off	✓	-
Presence test	On/Off	✓	✓
Restart	Restart sensor	✓	✓
DALI reset	Set DALI reset values	✓	-
DALI default	Set DALI default values	✓	-
Factory settings (factory reset)	Reset device to factory settings.	✓	-

Quiescent mode

If quiescent mode is activated, the PlanoSpot 360 DALI-2 S will not send any event telegrams to the DALI bus. Quiescent mode has a time limit of 15 minutes.

Presence test mode

Presence test mode is used to test presence detection. Presence test mode can be activated with the theSenda B/app or with the theSenda P installation remote control (☑ button). When the test mode is set, the PlanoSpot 360 DALI-2 S switches directly to test mode:

- Every movement is indicated by the LED. The hold timer is temporarily set to 10 s and the dead timer is set to 0 s. The PlanoSpot 360 DALI-2 S sends event telegrams to the DALI bus in line with the configuration of the presence sensor.
- To ensure that the light is switched on regardless of the brightness, the PlanoSpot 360 DALI-2 S sends the lowest brightness value (0).
- Test mode ends automatically after 10 min. The hold timer and dead timer return to the values set before the test.

Restart

The restart can be initiated with the theSenda B/app or the theSenda P remote control (↺ button). The subsequent start-up phase takes around 30 seconds. This phase is indicated by the LED, start-up phase flashing pattern, see section 4.6 Display.

DALI reset

All DALI variables are set to the reset values in accordance with IEC 62386-103/303/304.

DALI default

All DALI variables are set to the default values in accordance with IEC 62386-103/303/304. Please note: This also means that the short address will be reset.

Factory settings

This control command resets all parameters of the PlanoSpot 360 DALI-2 S to the factory settings and sets all DALI variables incl. memory bank entries to the default values in accordance with IEC 62386-103/303/304.

Please note: This also means that the short address will be reset.

The PlanoSpot 360 DALI-2 S presence sensor is supplied with the following parameter values:

Parameter	Value
Room correction factor Int/2	0.3
Room correction factor Inn/3	0.3
Room correction factor Mid/4	0.3
Room correction factor Win/5	0.3
Detection sensitivity (PIR)	3
Detection zone	Standard
Operating mode	0x00
IR group address A	I
IR group address B	II
IR group address C	III
IR group address D	All
IR group address E	All
LED display – no short address	Flashing permitted

7.2 Settings via the DALI bus

All of the parameters* and control commands described above can also be set by the multi-master application controller via the DALI bus. They are stored in the memory bank.

* Exceptions: "Brightness measurement value Int/2, Inn/3, Mid/4, Win/5" and "LED display – no short address" parameters. These parameters cannot be transferred via the DALI bus (see table in section 7.1.1).

7.3 Status messages via the DALI bus

The "QUERY INPUT DEVICE ERROR" command can be used to query the error status of the PlanoSpot 360 DALI-2 S (no response means no error):

Bit	Name	Value	Measures
0	Checksum_Error_Info	1 = Yes	Return the PlanoSpot 360 DALI-2 S for repair
1	Reserve	1 = Yes	
2	Checksum_Error_Parameter	1 = Yes	Reset to factory settings
3	Kein_HTS_Code	1 = Yes	Return the PlanoSpot 360 DALI-2 S for repair
4	EEPROM_Error	1 = Yes	Return the PlanoSpot 360 DALI-2 S for repair
5	Checksum_Error_DALI	1 = Yes	Reset to DALI default values
6	Reserve	1 = Yes	
7	instanceError	1 = Yes	Further queries are required, see below

In the event of instanceError, the "QUERY INSTANCE ERROR" command must be executed for the "Occupancy sensor", "Light sensor" and "Button instance" instances:

- If the "Occupancy sensor" instance returns an error notification: Return the PlanoSpot 360 DALI-2 S for repair.
- If the "Light sensor" instance returns an error notification: Return the PlanoSpot 360 DALI-2 S for repair.
- If the button instance returns an error notification: Check the remote control, push buttons.

8 Light measurement

8.1 Light measurement

The mixed light measurement measures artificial light and daylight. It provides consistent measurement results regardless of the light source. The artificial light from fluorescent lamps and LEDs is detected correctly despite the discrete spectrum. The light measurement device is located under the lens and receives diffuse light as a result.

The PlanoSpot 360 DALI-2 S has 3 light measurements:

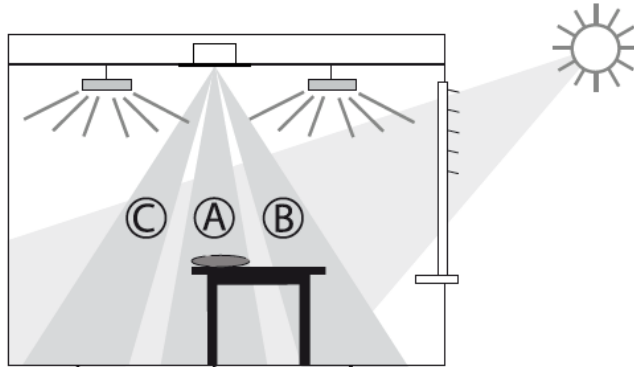

The light guide is designed in such a way that the light measurement covers an opening angle of approx. $\pm 40^\circ$ below the PlanoSpot 360 DALI-2 S and to the side.

The central light measurement detects the brightness directly below the "Middle brightness value" detector (A), while the other two light measurements detect the brightness close to the window ("Window brightness value"; B) or in the interior ("Interior brightness value"; C). The installation location is the reference point for the lighting level.

The measured brightness value can be adapted to the conditions in a room with the room correction factor. The brightness measurement transmitted for instance 2 to 5 is thus the measured brightness value / room correction factor.

See also the description of the room correction factor on page 14.

The measurement range of the light measurement is around 10 to 10,000 lux.

8.2 Determining a value via the DALI bus

According to DALI standard IEC 62386-103/304, the value of a light sensor instance is obtained either by querying directly or by evaluating the events.

8.2.1 Direct queries

The following steps must be carried out in order to query the value directly:

1. Address the DALI telegram "QUERY INPUT VALUE" to the desired device and with the desired instance number of a light sensor.
2. Multiply the returned value by 64 and save in a variable of at least 16 bits.
3. Address the DALI telegram "QUERY INPUT VALUE LATCH" to the previous device with the previous instance number.
4. Divide the returned value by 4 and add to the previous variables.

Example as pseudo code:

```
inputValue = QUERY_INPUT_VALUE()  
Variable = inputValue × 64  
inputValue = QUERY_INPUT_VALUE_LATCH ()  
Variable = Variable + inputValue ÷ 4
```

8.2.2 Evaluating events

A light sensor instance event can be triggered cyclically or in the case of certain changes to the value. The following steps are necessary in order to present the value that has been received in lux:

1. Extract the 10-bit event information from the 24-bit light sensor event telegram that has been received and save it in a variable of at least 16 bits.
2. The variable must then be multiplied by 16 in order to present the value in lux.

Example as pseudo code:

```
inputValue = EVENT_INFO  
Variable = inputValue × 16
```



As the event information is limited to 10 bits, only increments of 16 lux are possible. If a more precise value is required, this can be queried directly in full resolution. See 8.2.1 Direct queries

9 Operating modes

The PlanoSpot 360 DALI-2 S presence sensor is an input device and is exclusively intended to provide information about room occupancy and motion detection in accordance with IEC 62386 Part 303 (movement based sensor) as well as brightness values in accordance with IEC 62386 Part 304 to a higher-level controller via the DALI bus. The controller is responsible for the full range of functionality, including switching, constant lighting control, fully automatic/semi-automatic, manual override, scenes, etc.

The PlanoSpot 360 DALI-2 S is delivered and operated with operating mode 0x00 ex works.

9.1 Memory bank 2 – occupancy sensor

The parameters of occupancy sensor instance 0 and 1 – which are not defined by DALI-2 – are stored in memory bank 2.

Address	Description	Default value (factory)	RESET value	Memory type
0x00	Address of last position in this MB	0x03	no change	ROM
0x01	Indicator byte (defined by manufacturer) – version of the memory bank	0x01	no change	ROM
0x02	Memory bank lock byte	0xFF	0xFF	NVM
0x03	Detection sensitivity	0x03	0x03	NVM
0x04-0xFF	Not implemented / Reserved	Response NO	no change	ROM

The value range for the "Detection sensitivity" instance variables is 1 to 5, see section 7.1.1 Parameters.

9.2 Memory bank 3–6 – light sensors

The parameters of light sensor instances 2 to 5 are stored in memory banks 3–6. In the same way that the light sensor instances do not differ in terms of their function, the structure of the corresponding memory banks is also the same.

Address	Description	Default value (factory)	RESET value	Memory type
0x00	Address of last position in this MB	0x03	no change	ROM
0x01	Indicator byte (defined by manufacturer) – version of the memory bank	0x01	no change	ROM
0x02	Memory bank lock byte	0xFF	0xFF	NVM
0x03	Room correction factor	0x1E	0x1E	NVM
0x04-0xFF	Not implemented / Reserved	Response NO	no change	ROM

The value range for the "Room correction factor" variables is 5 to 200. To calculate the actual "Room correction factor" value, divide by 100.

The assignment of the memory banks to the light sensors is as follows:

- Instance 2 provides integral brightness values: Memory bank 3
- Instance 3 provides interior brightness values: Memory bank 4
- Instance 4 provides middle brightness values: Memory bank 5
- Instance 5 provides window brightness values: Memory bank 6

9.3 Memory bank 7–11 – button instance

The IR group addresses of button instances 6 to 13 are stored in memory banks 7–11.

Memory bank 7

Address	Description	Default value (factory)	RESET value	Memory type
0x00	Address of last position in this MB	0x03	no change	ROM
0x01	Indicator byte (defined by manufacturer) – version of the memory bank	0x01	no change	ROM
0x02	Memory bank lock byte	0xFF	0xFF	NVM
0x03	IR group address button instance 6–7	0x01	0x01	NVM
0x04-0xFF	Not implemented / Reserved	Response NO	no change	ROM

The value range for the "IR group address button instance 6–7" instance variables is I (0x01) to VIII (0x80) and All (0xFF), see also section 7.1.1 Parameters.

Memory bank 8

Address	Description	Default value (factory)	RESET value	Memory type
0x00	Address of last position in this MB	0x03	no change	ROM
0x01	Indicator byte (defined by manufacturer) – version of the memory bank	0x01	no change	ROM
0x02	Memory bank lock byte	0xFF	0xFF	NVM
0x03	IR group address button instance 8–9	0x02	0x02	NVM
0x04-0xFF	Not implemented / Reserved	Response NO	no change	ROM

The value range for the "IR group address button instance 8–9" instance variables is I (0x01) to VIII (0x08) and All (0xFF), see also section 7.1.1 Parameters.

Memory bank 9

Address	Description	Default value (factory)	RESET value	Memory type
0x00	Address of last position in this MB	0x03	no change	ROM
0x01	Indicator byte (defined by manufacturer) – version of the memory bank	0x01	no change	ROM
0x02	Memory bank lock byte	0xFF	0xFF	NVM
0x03	IR group address button instance 10–11	0x04	0x04	NVM
0x04-0xFF	Not implemented / Reserved	Response NO	no change	ROM

The value range for the "IR group address button instance 10–11" instance variables is I (0x01) to VIII (0x08) and All (0xFF), see also section 7.1.1 Parameters.

Memory bank 10

Address	Description	Default value (factory)	RESET value	Memory type
0x00	Address of last position in this MB	0x03	no change	ROM
0x01	Indicator byte (defined by manufacturer) – version of the memory bank	0x01	no change	ROM
0x02	Memory bank lock byte	0xFF	0xFF	NVM
0x03	IR group address button instance 12	0xFF	0xFF	NVM
0x04-0xFF	Not implemented / Reserved	Response NO	no change	ROM

The value range for the "IR group address button instance 12" instance variables is I (0x01) to VIII (0x08) and All (0xFF), see also section 7.1.1 Parameters.

Memory bank 11

Address	Description	Default value (factory)	RESET value	Memory type
0x00	Address of last position in this MB	0x03	no change	ROM
0x01	Indicator byte (defined by manufacturer) – version of the memory bank	0x01	no change	ROM
0x02	Memory bank lock byte	0xFF	0xFF	NVM
0x03	IR group address button instance 13	0xFF	0xFF	NVM
0x04-0xFF	Not implemented / Reserved	Response NO	no change	ROM

The value range for the "IR group address button instance 13" instance variables is I (0x01) to VIII (0x08) and All (0xFF), see also section 7.1.1 Parameters.

9.4 Start-up behaviour

When the PlanoSpot 360 DALI-2 S is connected to a power supply or if it is restarted, it goes into the start-up phase for a defined period of time before switching to normal operation. This is indicated by the LED flashing.

After the power supply is switched on (restoration of the bus supply), a motion sensor element may provide signals as a result of physical properties until the PIR has stabilised. It is therefore not possible to determine whether signals occurring immediately after start-up indicate genuine presence or are merely transient electrical responses.

The PlanoSpot 360 DALI-2 S suppresses the signals from the motion sensor element during the start-up phase (30 s). After 30 s (end of the start-up phase), the PlanoSpot 360 DALI-2 S sends the current events in line with the current settings.

To ensure that anyone present is not left standing in the dark for 30 s after a bus failure, the higher-level controller should always switch on the light when the bus supply is restored. In accordance with IEC 62386-103, the PlanoSpot 360 DALI-2 S can send a telegram with the information "Power Notification" following start-up if necessary. This telegram will contain information about a bus failure or restart of the PlanoSpot 360 DALI-2 S. The higher-level controller can then decide whether or not to switch on the light following restoration of the bus supply.

9.5 Addressing

The addressing of the PlanoSpot 360 DALI-2 S (assignment of short addresses) is carried out on the basis of the algorithm defined in IEC 62386-102, Annex A1 (informative). The 24-bit commands do not overlap with the 64 devices in the 16-bit address space.

9.6 Presence

The PlanoSpot 360 DALI-2 S has two instances with regard to room occupancy and motion detection:

- Instance 0 provides information about the standard detection zone
- Instance 1 provides information about the reduced detection zone on the DALI bus in accordance with IEC 62386 Part 303.

9.7 Brightness

The PlanoSpot 360 DALI-2 S has four instances for brightness measurement:

- Instance 2 provides integral brightness values
- Instance 3 provides interior brightness values
- Instance 4 provides middle brightness values
- Instance 5 provides window brightness values

on the DALI bus in accordance with IEC 62386 Part 304.

The integral brightness value is the average of the interior, middle and window brightness measurements.

9.8 Button function

The PlanoSpot 360 DALI-2 S partially supports the button instances defined in IEC 62386 Part 301. The theSenda S or theSenda B user remote controls can be used to dim or switch the lamps, to control the blinds, or to execute additional functions. The remote control commands are sent to the PlanoSpot 360 DALI-2 S via the IR interface. The PlanoSpot 360 DALI-2 S sends this information via the DALI bus to the higher-level controller. Using this information, the controller can trigger the desired actions.

The "push button input events" and "event timer settings" are partially supported in line with IEC 62386 Part 301.

The following "events" are supported:

- Short press
- Long press start / repeat / stop ¹
- Double press
- Button free / stuck ¹

The following "timer settings" are supported:

- tDouble
- tRepeat ¹
- tStuck ¹

¹⁾ is not supported by the Scene 1 and 2 buttons.

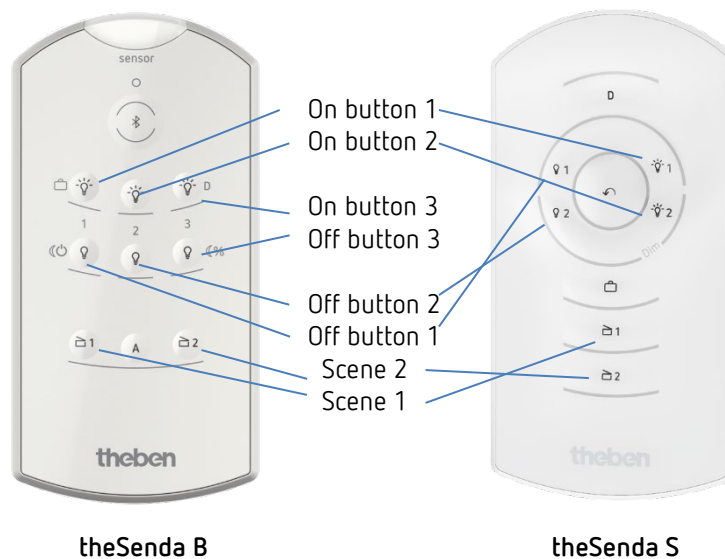

The PlanoSpot 360 DALI-2 S provides "events" relating to the individual buttons on the DALI bus in line with IEC 62386 Part 301 via the following instances:

- Instance 6/8/10 provides events relating to any On button with the configured IR group address
- Instance 7/9/11 provides events relating to any Off button with the configured IR group address
- Instance 12 provides events relating to the Scene 1 button with the configured IR group address
- Instance 13 provides events relating to the Scene 2 button with the configured IR group address

Events are only triggered if the IR group address set in the relevant memory bank matches the IR group address for the remote control.

Further information about setting the IR group addresses for the remote control can be found in the operating instructions for the theSenda B or theSenda S.

10 Accessories

Back box 75B WH
 Item no.: 9070796
 Details > www.theben.de/en



PlanoCover 76 BK
 Item no.: 9070592
 Details > www.theben.de/en



PlanoCover 76 SR
 Item no.: 9070592
 Details > www.theben.de/en



theSenda B
 Item no.: 9070985
 Details > www.theben.de/en



theSenda P
 Item no.: 9070910
 Details > www.theben.de/en



theSenda S
Item no.: 9070911
Details > www.theben.de/en



11 Contact

Theben AG

Hohenbergstr. 32

72401 Haigerloch

GERMANY

Phone +49 7474 692-0

Fax +49 7474 692-150

Hotline

Phone +49 7474 692-369

hotline@theben.de

Addresses, telephone numbers, etc.

www.theben.de/en